

5-25ML ORAL LIQUID FILLING PRODUCTION LINE

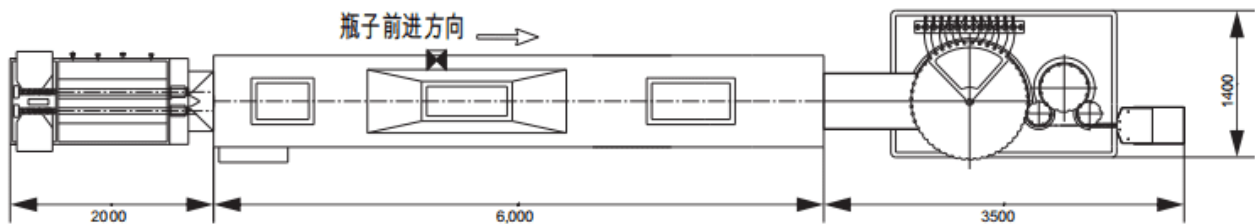
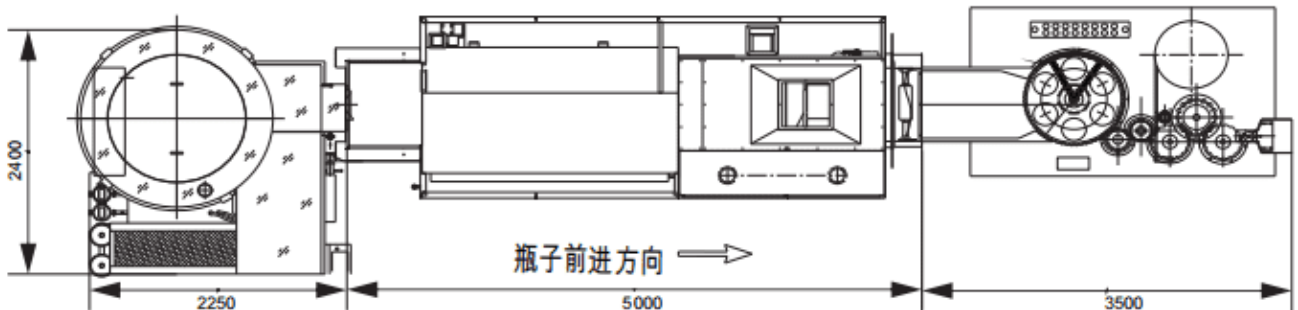
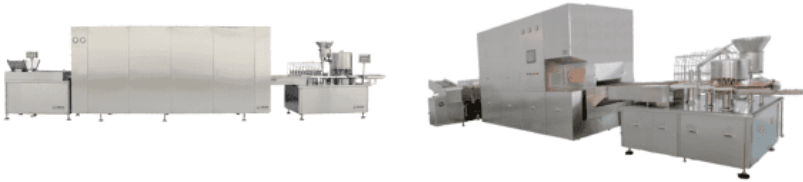

Equipment Brief introduction:

This production line suitable for 5-25ml tube-type bottle oral liquid Washing Drying, Filling and capping(Roll). Production line composed by SGLCX Vertical ultrasonic wave washing machine, SGRHX Hot air circulation tunnel oven SGKZ Oral liquid filling capping(roll) machine. Can be connected for production line or stand-alone;

The technological process: Mesh belt into bottle, Ultrasonic wave washing, Three times water and air clean bottle inside and outside, Dry and sterilization, Filling and capping(roll);

This production line performance stable, operation is very simple, According to customer technological requirements configuration can satisfy different specifications and production speed.

Product No	APKKGZ-4	APK KGZ-12	APKKGZ-16

Applicable specification	5-25ml 60-80B/M	5-25ml 150-220B/M	5-25ml 300-400B/M
Production speed	60-80b/m	150-220b/m	300-400b/m
Filling error	±1-2%	±1-2%	±1-2%
Water pressure and water consumption	0.25-0.35MPa,0.5m ³ /h	0.25-0.35MPa,1.5m ³ /h	0.25-0.35MPa,1m ³ /h
Power supply Pysers	380/220V,8KW	380/220V,42KW	380/220V,80KW
urif compre s d ai pre sure and air co nsumption	0.6-0.8MPa,10m ³ /h	0.6-0.8MPa,45m ³ /h	0.6-0.8MPa,75m ³ /h
Exhaust volume	1000m ³ /h	2600m ³ /h	3200m ³ /h
Weight	650KG	3000KG	7500KG
Dimensions	5000×1300×1500mm	11000×1800×2000mm	12000×2500×2400mm



20-100ML ORAL LIQUID FILLING PRODUCTION LINE

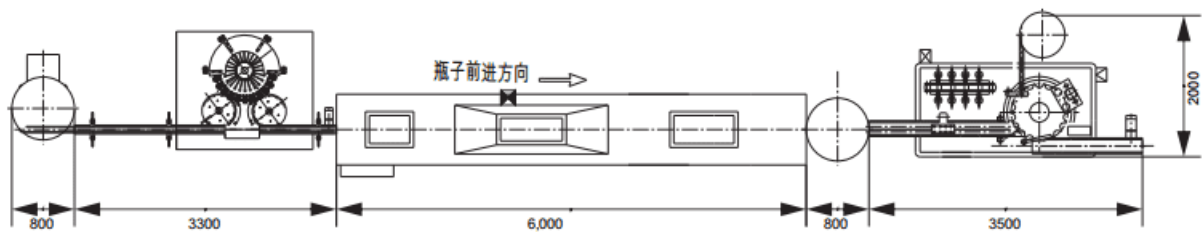
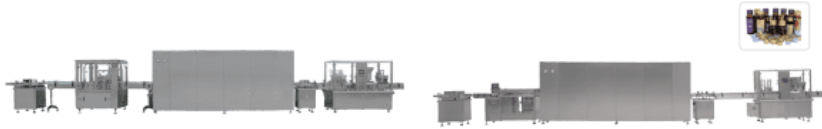

Equipment Brief introduction:

This production line suitable for 20-100ml metal screw thread cap glass bottle oral liquid Washing, Drying,

Production line composed by Washing machine, Tunnel oven, Liquid filling and capping(roll) machine, Can be connected for production line or stand-alone.

The technological process: Bottle feeding, Washing bottle, Dry and sterilization, Filling and capping (roll). Widely used in glass bottles of oral liquid, especially capping(roll) metal screw thread cap is our company patent structure, screw thread neat and smooth, Equipment performance stable, Operation is very simple.

According to customer technological requirements configuration can satisfy different specifications and

Product No	APKGZ-4	APKGZ-8
Applicable specification	20-100ml 40-60B/M	20-100ml 80-100B/M
Production speed	40-60 b/m	80-100 b/m
Filling error	±1-2%	±1-2%

20-100ML ORAL LIQUID FILLING PRODUCTION LINE (HIGH SPEED)

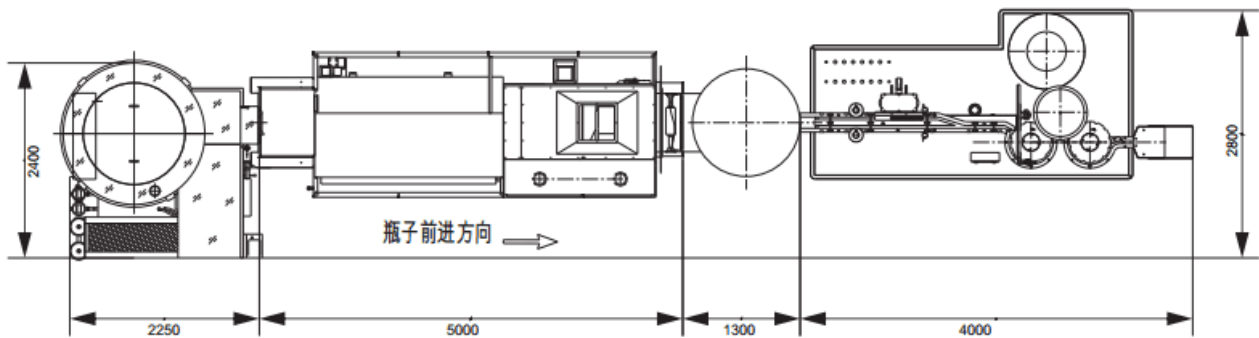

Equipment Brief introduction:

This production line suitable for 20-100ml metal screw thread cap glass bottle oral liquid Washing, Drying,

Production line composed by Washing machine, Tunnel oven, Liquid filling and capping(roll) machine, Can be connected for production line or stand-alone.

The technological process: Bottle feeding, Washing bottle, Dry and sterilization, Filling and capping (roll). Widely used in glass bottles of oral liquid, especially capping(roll) metal screw thread cap is our company patent structure, screw thread neat and smooth, Equipment performance stable, Operation is very simple.

According to customer technological requirements configuration can satisfy different specifications and

Product No	APKGZ-12
Applicable specification	20-100ml
Production speed	150-220B/M 150-220 b/
Filling error	$m \pm 1-2\%$